

KSUB

Control and monitoring unit

MANUAL

KSUB

CONTENTS

Description.....	2
KSUB Light.....	2
General system overview	3
Accessories	3
Connections	4
Damper wiring	5
Wiring for stand-alone mode	6
Wiring for network mode	7
Specification.....	8
Terminology	9
Operating instructions/troubleshooting	10

DESCRIPTION

The KSUB is a control and monitoring unit for ventilation system fire protection, designed to control fire dampers and an air handling unit (fan). It regularly monitors the end positions of the damper.

The KSUB can be used as a **stand-alone unit** or as a **slave unit** in a network with the SUSA or KSUA master unit.

- 4 fire dampers in 2 damper groups
- 2 smoke detector loops (max. 5 per loop)
- Manages 1 air handling unit (fan)
- 48 hour or 7 day interval for damper test
- Input for an external fire alarm or night mode
- A-alarm and B-alarm relay (fire alarm/sum alarm)
- Integrated transformer 230/24 VAC

Important.

Safety may be affected if the unit is used other than as specified in the manual.

KSUB LIGHT

The KSUB Light is a version of the KSUB which only has connections for:

- Dampers (DAMPER 1 & 2)
- Fire alarm (EXT)
- Network connection to SUSA/KSUA (IS-BUS)

GENERAL SYSTEM OVERVIEW

A typical example of network mode involving the SUSAs master unit and slave units is presented below. Follow the instructions to install the KSUB as a stand-alone unit or as a slave unit for the SUSAs or KSUA.

You can also visit our website oncontrol.se to use our product selection program.

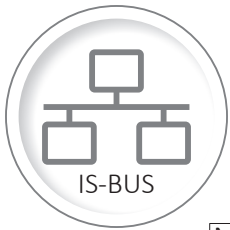

- Max. length of IS-BUS 1200 m
- Daisy chain with max. 20 m branch length
- Max. 32 slave units

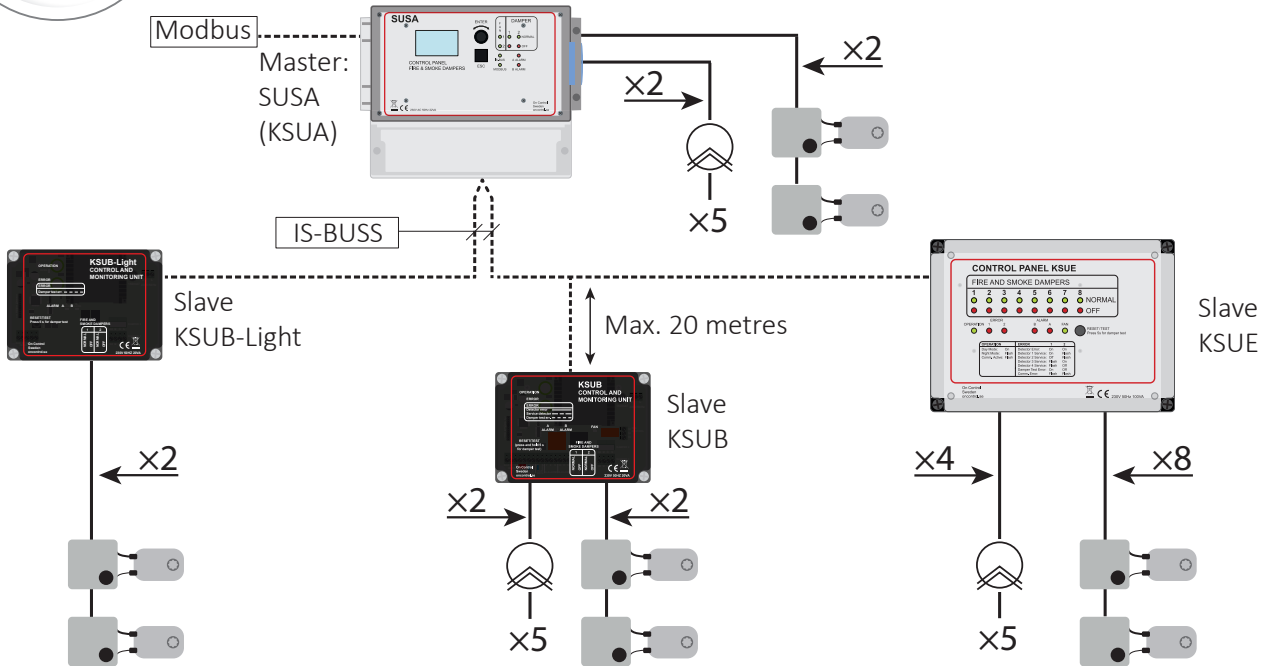

UNIT	FIRE DAMPER	SMOKE DETECTOR
SUSAs	4 (2X2)	10 (2X5)
KSUE	16 (8X2)	20 (4X5)
KSUB	4 (2X2)	10 (2X5)
KSUB Light	4 (2X2)	0

ACCESSORIES

KBOX

The KBOX connection box makes it much easier to connect the actuators to the control unit. There are labelled terminals and an integrated motor test button.

It is also easy to connect two actuators to a damper group (parallel connection).

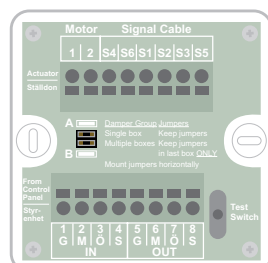

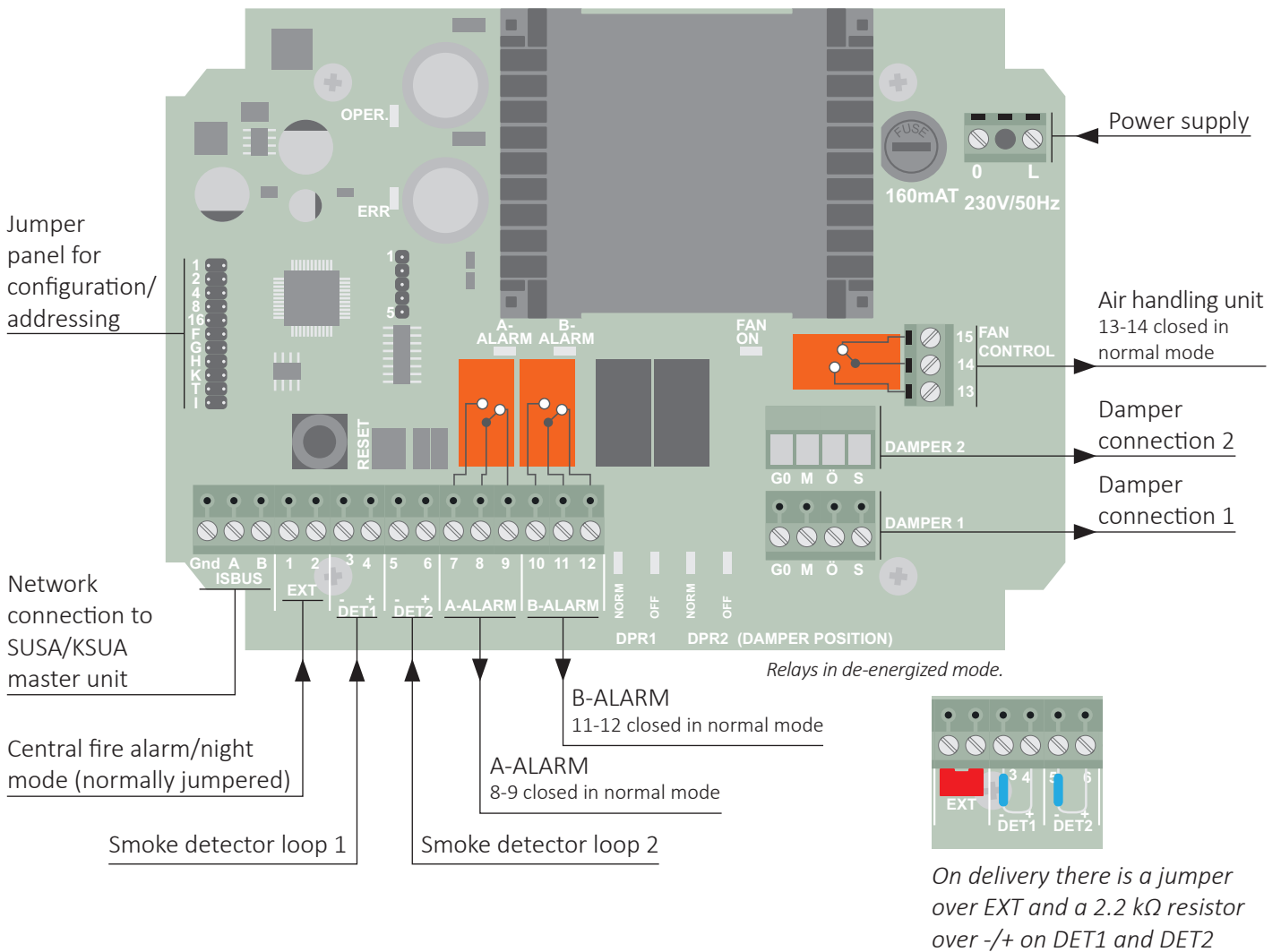

Wiring

The wiring is described in one of the tables below depending on whether the unit will be installed as a stand-alone unit or in network mode (slave unit for the SUSA/KSUA):

- Wiring for stand-alone mode on page 6
- Wiring for network mode on page 7

Cable recommendation

- The smoke detectors are connected with twisted pair (telephone type) cable, with no particular requirements in terms of cross-sectional area.
- The damper motor can be connected with EKKX 1x4x0.5 for example.
 - One damper per damper group max. 100 metres
 - Two dampers per damper group max. 50 metres
- The IS-BUS network can be connected with FKAR-PG 2x0.5.

Wiring - INDIVIDUAL

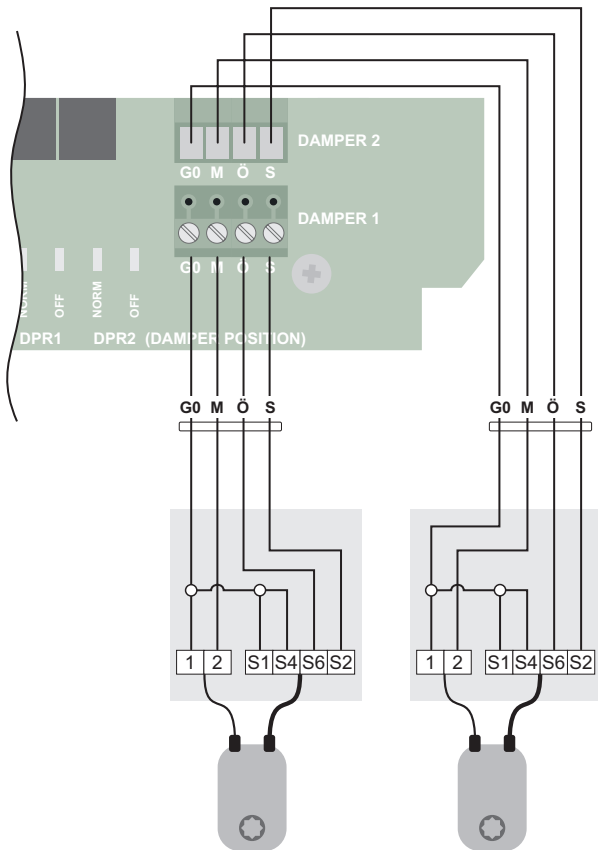

Wiring - PARALLELL

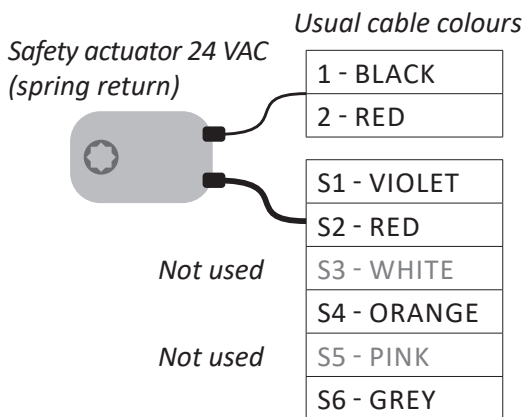
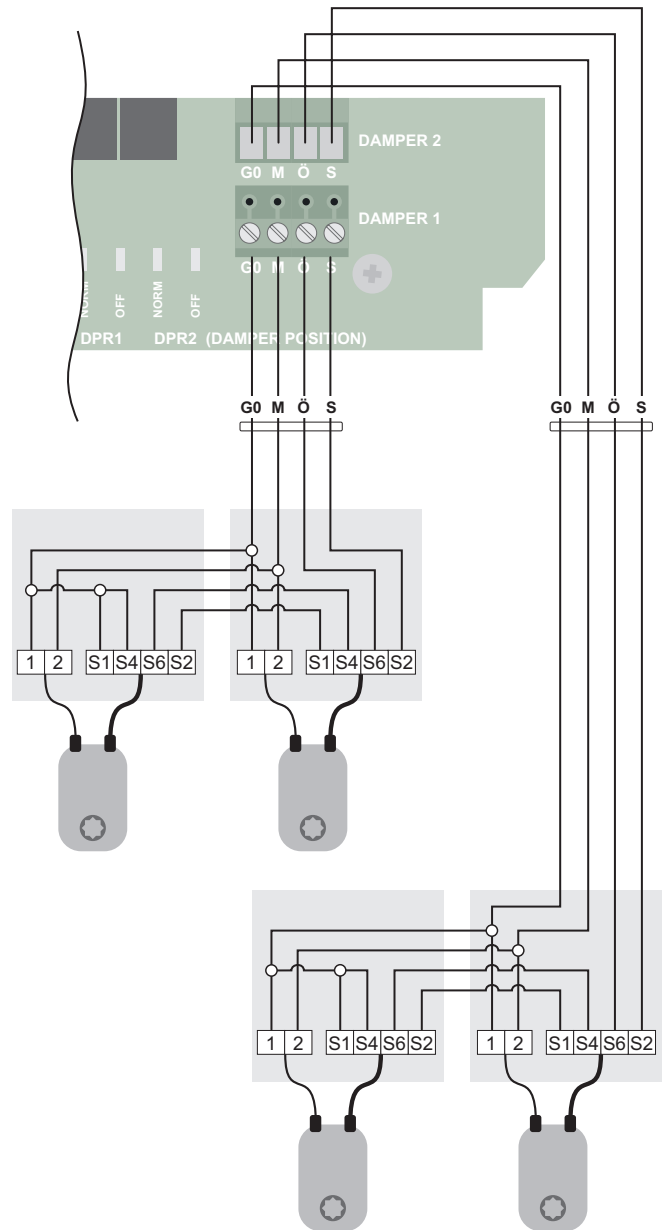

Connecting fire dampers

- Fire dampers are connected as illustrated above, with up to two dampers per damper group.
- The bypass/pressure relief damper type with spring return to the open position is only supported if the KSUB is used as a slave unit and the damper type is connected as a fire damper. The damper types must not be mixed within the same damper group.



TIP

To simplify wiring, you are recommended to use the KBOX accessory, which contains a circuit board with labelled terminals.



IMPORTANT!

If a single damper group is connected in stand-alone mode, DAMPER 1 must be used with jumper 4 ON.

WIRING FOR STAND-ALONE MODE





STAND-ALONE MODE





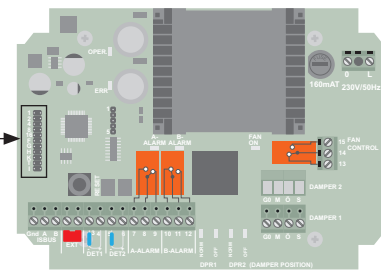

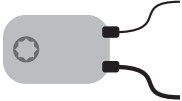
IMPORTANT!

In stand-alone mode, jumper H must be ON.



CONTROL OF EXTERNAL UNIT	TERM.	NAME	DESCRIPTION	JUMPER	JUMPER POSITION	
					FUNCTION WITH JUMPER ON	FUNCTION WITH JUMPER OFF
Fire damper 	G0, M, Ö, S	DAMPER1, DAMPER2	Fire damper 24 V with spring return is installed as described in Damper wiring on page 5. Max. 4 dampers divided between 2 damper groups. Total max. 20 VA. Damper test interval starts after 10 hours. This happens after each restart. Operation max 20 VA / 3 min / Standby max 8 VA / 48 h.	4	DAMPER 2 NOT used	Both damper groups used
				G	Sequential damper test	Simultaneous damper test
				T	Damper test interval: 1 week	Damper test interval: 48 hours
Air handling unit 	13, 14, 15	FAN CONTROL	In normal mode, terminals 13-14 are closed and they switch after an A-alarm or damper test depending on the jumper configuration. Voltage-free changeover relay, max. 5 A/250 VAC.	2	Fan DOES NOT stop in "night mode"	Fan stops in "night mode"
				16	NO stop of fan during damper test	Stop of fan during damper test
				F	NO delay when fan stopped	Fan stopped 30 seconds before the damper test starts

INPUTS	TERM.	NAME	DESCRIPTION	JUMPER	FUNCTION WITH JUMPER POSITION	
					FUNCTION WITH JUMPER ON	FUNCTION WITH JUMPER OFF
Smoke detector 	3(-) 4(+)	DET 1	Replace existing resistor with smoke detector similar to UG3-0. Max. 5 in a loop per input. The last smoke detector is terminated with a 2.2 kΩ resistor.	8	2 detector zones ■ DET 1 controls DAMPER 1 ■ DET 2 controls DAMPER 2	1 detector zone ■ Controls both damper groups
	5(-) 6(+)	DET 2				
Fire alarm/night mode 	1-2	EXT	Normally closed. Activated by a voltage-free external circuit breaker. Controls all function groups. A damper test can take place in night mode.	1	Night mode input	Fire alarm input
				K	Automatic fire alarm reset when EXT closes	Manual fire alarm reset

OUTPUTS (ALARM)	TERM.	NAME	DESCRIPTION
Fire alarm 	7, 8, 9	A-ALARM	In normal mode, terminals 8-9 are closed and they switch after a fire alarm from EXT or DET. Voltage-free changeover relay, max. 5 A/250 VAC.
Sum alarm 	10, 11, 12	B-ALARM	In normal mode, terminals 11-12 are closed and they switch after ■ a detector fault/service ■ a damper fault and ■ a fire alarm. Voltage-free changeover relay, max. 5 A/250 VAC.

POWER SUPPLY	TERM.	NAME	DESCRIPTION
230 VAC 50 Hz	0, L	230 V/50 Hz	Connected with permanent cabling and isolating switch.

WIRING FOR NETWORK MODE

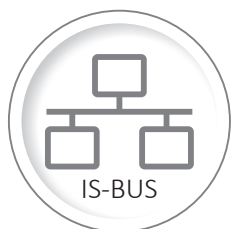

NETWORK MODE



IMPORTANT!

This page describes how to install the KSUB in **network mode** with the SUSA or KSUA master unit, and is not applicable to stand-alone mode. Jumper “H” must be OFF.

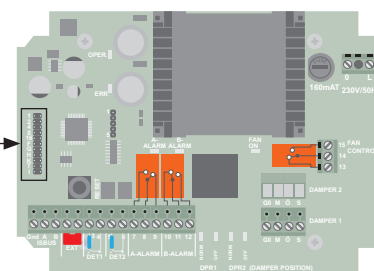

Addressing in KSUB 0 to 31

0	1	2	3	4	5	6	7	8	9	10	11	12	13	14	15
16	17	18	19	20	21	22	23	24	25	26	27	28	29	30	31

Wiring

CONTROL OF EXTERNAL UNIT	TERM.	NAME	DESCRIPTION
Fire/evacuation damper 	G0, M, Ö, S	DAMPER1, DAMPER2	Fire or evacuation damper 24 VAC with spring return. Max. 4 dampers divided between 2 damper groups, total max. 25 VA. Installed according to Damper wiring on page 5. Damper tests are performed by the master unit. Operation max 20 VA / 3 min / Standby max 8 VA / 48 h The damper groups must be configured in the master unit.
Air handling unit 	13, 14, 15	FAN CONTROL	<ul style="list-style-type: none"> The lowest slave unit address mirrors the function from master unit relay number 1. The next slave address mirrors the function from relay number 2 in the master unit. Voltage-free changeover relay, max. 5 A/250 VAC.

INPUTS	TERM.	NAME	DESCRIPTION
Smoke detector 	3(-) 4(+) 5(-) 6(+)	DET 1 DET 2	Replace existing resistor with smoke detector similar to UG3-0. Max. 5 per input. The last smoke detector is terminated with a 2.2 kΩ resistor. The detector inputs must be configured from the master unit.
Fire alarm 	1-2	EXT	Normally closed and activated by a voltage-free external circuit breaker. Controls the entire system. The function only exists if detector group 1 is activated in the master unit. Keep the resistor in the terminal.
Network 	Gnd, A, B	IS-BUS	Network connection to the SUSA or KSUA master unit, which can ONLY be connected to the IS-BUS . Daisy chaining between units with Gnd to Gnd, A to A and B to B. Addressing in the KSUB is as shown in the table above. The unit can then be configured in the master unit. If relevant, the IS-BUS is terminated with jumper I but only for the two most remote units in the network.

POWER SUPPLY	TERM.	NAME	DESCRIPTION
230 VAC 50 Hz	0, L	230 V/50 Hz	Connected with permanent cabling and isolating switch.

SPECIFICATION

Installation

Intended to be attached to a wall indoors.

Power supply

230 VAC 50 Hz 30 VA. Fused with max 10 A / min 2 A.

The mains voltage may vary $\pm 10\%$

Transient voltages up to overvoltage category II.

Fuses

There is a T160 mA, 250 V fuse (FS1) on the motherboard.

The fuse is to the right of the mains transformer. The holder is the bayonet type. To remove the fuse, press down and turn a quarter turn anticlockwise.

Protection class

IP65

Ambient temperature

Max +40 °C, min -10 °C

Altitude up to 2000 m

Max relative humidity 80% at temperatures up to 31 °C

Max relative humidity falls in a linear fashion to 50% at 40 °C

Weight

1.5 kg

Dimensions

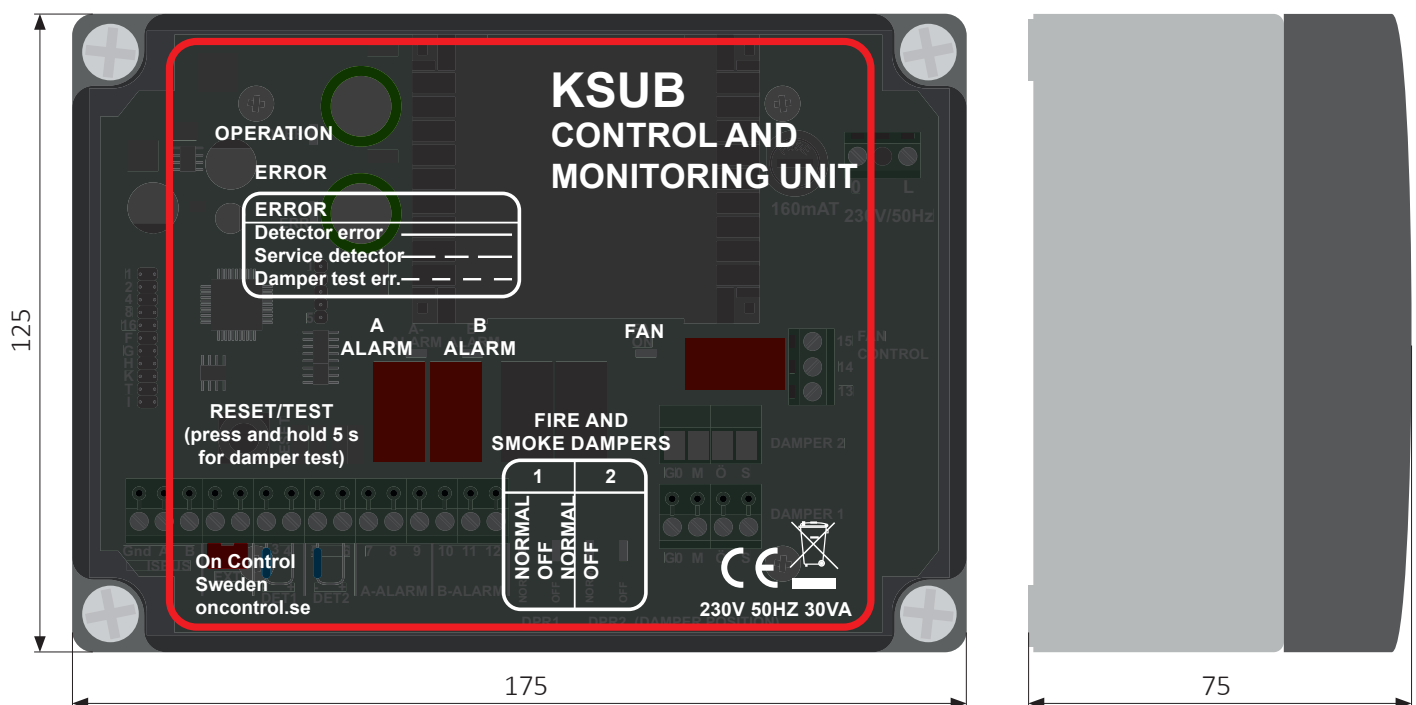

Outputs

- B-alarm – voltage-free changeover contact, max. 8 A/250 V. Terminal numbers 10, 11, 12.
- A-alarm – shared by all smoke detectors and EXT. Voltage-free changeover contact, max. 8 A/250 V. Terminal numbers 7, 8, 9.
- Fan (FAN) – voltage-free changeover contact, max. 8 A/250 V. Terminal numbers 13, 14, 15.
- Damper group 1
- Damper group 2

Inputs

- IS network bus to the SUSA or KSUA master unit.
- External fire alarm (EXT) or night mode input. Controls both damper groups. Terminals 1, 2.
- Detector 1. Terminals 3, 4
- Detector 2. Terminals 5, 6
- Input for 230 V/50 Hz

Pollution degree

Pollution degree 2 is valid for the intended environment.

Isolating switch

The installation must have an isolating switch or circuit breaker.





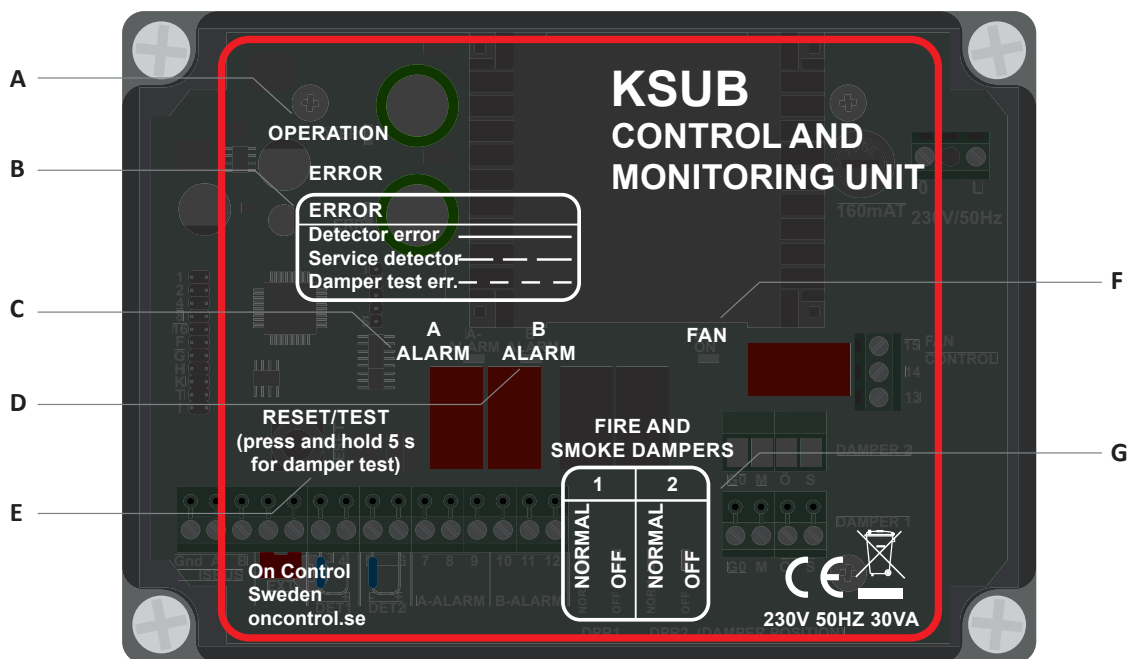

It must be easy to access at a suitable location.

It must be labelled as the isolating device for the equipment.

TERMINOLOGY

Ventilation dampers	Fire damper with 24 VAC motor, closed by spring to the safe position (closed).
Evacuation/pressure relief/bypass damper	Fire damper with 24 VAC motor, opened by spring to the safe position (open).
Normal mode	Means that ventilation dampers are open and evacuation dampers are closed.
Night mode	All damper types are closed. Used for example when the ventilation system is shut down to save energy. The fire damper is moved to the safe position and opens when the NIGHT input closes again. Damper tests can take place during this time.
Stand-alone mode	The unit is not connected via the IS-BUS network to a master unit. It is instead completely stand-alone and alarms are indicated via LED and the voltage-free changeover relay. The jumper panel is used for configuration.
Network mode	The SUSA or KSUA master unit communicates all alarms, function tests, etc. to the slave units via the IS-bus. Max. 32 slaves.
Parallel connection	This means two dampers connected to a single damper group (DAMPER). An individual damper error will affect the NORMAL/OFF indication for the damper group (in network mode this appears in the master unit).
Jumper panel	For installations in stand-alone mode the jumper panel is used to configure the unit. For installations in network mode the jumper panel is used for slave unit addressing.



FUNCTION	DESCRIPTION
A OPERATION (OPER.)   	<p>Green LED showing that the unit is receiving power and indicating day/night mode or communication.</p> <p>Constant = day mode.</p> <p>Slow flashing = night mode.</p> <p>Rapid flashing = communication via IS-BUS.</p>
B ERROR (ERR)   	<p>This LED uses three different flashing sequences to indicate three different alarms.</p> <ul style="list-style-type: none"> ▪ Constant if the detector loop is broken <i>Check that:</i> <ul style="list-style-type: none"> ▪ The terminating resistor is correct in the last detector of the loop with the problem. It should be 2200 Ω, 0.6 W. ▪ If the input is not used, a resistor of 2200 Ω must be installed to replace the detectors. ▪ Break in cable ▪ Loose contact in the detector bases ▪ Check the wiring to the detectors. ▪ Polarity! ▪ Alternating short and long flashes if there is a service alarm (dirty smoke detector) The indication is delayed by one hour to prevent false alarms. When the alarm is reset, the delay is deactivated to make it possible to confirm immediately that the alarm has been cleared. <i>Check that:</i> <ul style="list-style-type: none"> ▪ There is no dirt on one or more detectors. Indicated by a yellow LED on the affected detector if the detector has a service alarm function. Vacuum-clean or, in the worst case, replace the detector head. ▪ Rapid flashing if the damper test fails <i>Check that:</i> <ul style="list-style-type: none"> ▪ If a single damper group is connected, DAMPER 1 is used for the connection and jumper 4 is ON. ▪ Connected DAMPER (1, 2) groups indicate NORMAL (green). Perform a manual (E) damper test and check that the relevant DAMPER indicates OFF (red) within 30 seconds after NORMAL (green) goes off. The indication must then return to NORMAL within 200 seconds.

	FUNCTION	DESCRIPTION
C	A-ALARM	<p>Both smoke detector loops are indicated using the same LED. If the LED is red, a detector has been triggered. The associated relay is closed.</p> <p>Check that:</p> <ul style="list-style-type: none"> ▪ The EXT input is jumpered or closed by an external control unit ▪ None of the detector loops is short circuited ▪ An alarm from a detector is indicated with a red LED on the detector
D	B-ALARM	<p>A B-alarm is indicated by the red LED and the associated relay output is closed when the following events occur:</p> <ul style="list-style-type: none"> ▪ Break in any of the detector loops ▪ Error during function test ▪ Service alarm in any of the detector loops ▪ Damper in incorrect position in normal mode ▪ Wiring error <p>Check that:</p> <ul style="list-style-type: none"> ▪ There are no other alarms indicated by the LEDs ▪ No damper has closed incorrectly ▪ The dampers are wired correctly <p>In particular, take care that G and M are not the wrong way round.</p>
E	RESET (TEST)	<p>RESET – press quickly to reset all alarms.</p> <p>TEST – for a manual damper test, hold down the button for longer than five seconds. The test starts after you release the button and the fan relay (FAN CONTROL) switches off. There is a configurable delay before the damper test to reduce any duct pressure or to allow the reheater to cool.</p> <p>A RESET is required after night mode</p> <p>Unwanted locking can take place between the KSUB and the air handling unit in response to a night mode signal (from the air handling unit) unless jumper 2 is ON.</p>
F	FAN CONTROL	<p>Normal mode for the air handling unit is indicated with the green FAN CONTROL LED when the relay is closed 13-14.</p>
G	DAMPER 1, DAMPER 2	<p>Indicates the end position of the safety actuator for the relevant damper group DAMPER 1, 2 (DPR).</p> <ul style="list-style-type: none"> ▪ Green LED (NORMAL) indicates the position in normal mode <ul style="list-style-type: none"> ▪ This means that the ventilation damper (fire damper) is in the open blade position. ▪ The evacuation/pressure relief/bypass damper is in the closed blade position (network mode only). ▪ Red LED (OFF) indicates the safe position of the damper. <ul style="list-style-type: none"> ▪ This means that the ventilation damper (fire damper) is in the closed blade position. ▪ The evacuation/pressure relief/bypass damper is in the open blade position (network mode only). <p>If two dampers are connected in parallel in the same damper group, the indication is the same for both dampers.</p> <p>The dampers do not open.</p> <p>Check that:</p> <ul style="list-style-type: none"> ▪ There are no other alarms on the front panel ▪ The damper motor is connected correctly. <p>A manual reset is required after an automatic function test.</p> <p>The “fan lock” output has probably been connected to the wrong input in the ventilation system, which has locked itself as a result.</p>



**Disposal of waste electrical and electronic equipment
(applies to the EU and other European countries with a dedicated collection system)**

If this symbol appears on the product or its packaging, the product must not be treated as household waste. Instead, it must be sent to a collection point that recycles electrical and electronic equipment. By making sure this product is correctly processed, you will help to prevent the negative impact on the environment and on human health that could result from inappropriate waste handling. Recycling helps to conserve natural resources. To find out more about recycling this product you can contact your local authority, your cleaning contractor or the dealer you purchased the product from.

PROFCON AB

Victor Hasselblads gata 9
421 31 Västra Frölunda
Sweden

Tel: +46 (0)33 25 65 70

Web: oncontrol.se

On Control is a registered trademark belonging to Profcon AB