



SUSA

Control and monitoring unit

MANUAL

SUSA

CONTENTS

Description.....	2
General system overview	3
Accessories	3
Maximum configuration	3
Connections	4
Damper wiring	5
Wiring with KBOX.....	6
Inputs	7
First startup.....	8
During startup.....	9
Menu system	11
Specification.....	14
Terminology	15
Operation/troubleshooting	16

DESCRIPTION

The SUSA is a control and monitoring unit designed to control various types of fire/smoke dampers and fans in a flexible way.

FW 3.0 and later is not compatible with the older expansion unit SUSB.

- 2 damper groups, max 4 dampers.
- Two detector groups.
- 2 fan groups.
- Built-in locking of fans.
- Automatic damper test.
- Separate test of smoke extraction fan.
- An alarm panel can be connected.
- Real time clock with battery backup.
- Separate clock for smoke extraction fan test.
- A pressure switch can be connected to test the smoke extraction fan.
- External input for central fire alarm system.
- Dampers can be closed via external inputs.
- Damper position indication.
- Network connection for slave units.
- Modbus RTU network connection for central monitoring.
- Log function for all fault types.
- Log function for tests.
- Audible alarm.
- Compact plastic case.
- Integrated transformer.
- 24 V supply to actuator.

Important.

Safety may be affected if the unit is used other than as specified in the manual.

Valid from program version FW3.0.2

GENERAL SYSTEM OVERVIEW

The following diagram is a typical example of network mode between the SUSA master unit and slave units. KBOX replaces the required connection point between the motor and the control panel. It has no functional requirements and makes installation much easier. There is always one KBOX for each damper. You can also visit our website oncontrol.se to use our product selection program.

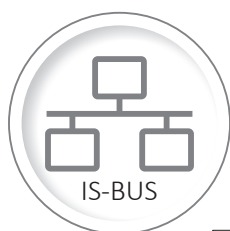

- Max length of IS-BUS 1200 m
- Daisy chain with max branch length 20 m
- Max 32 slave units

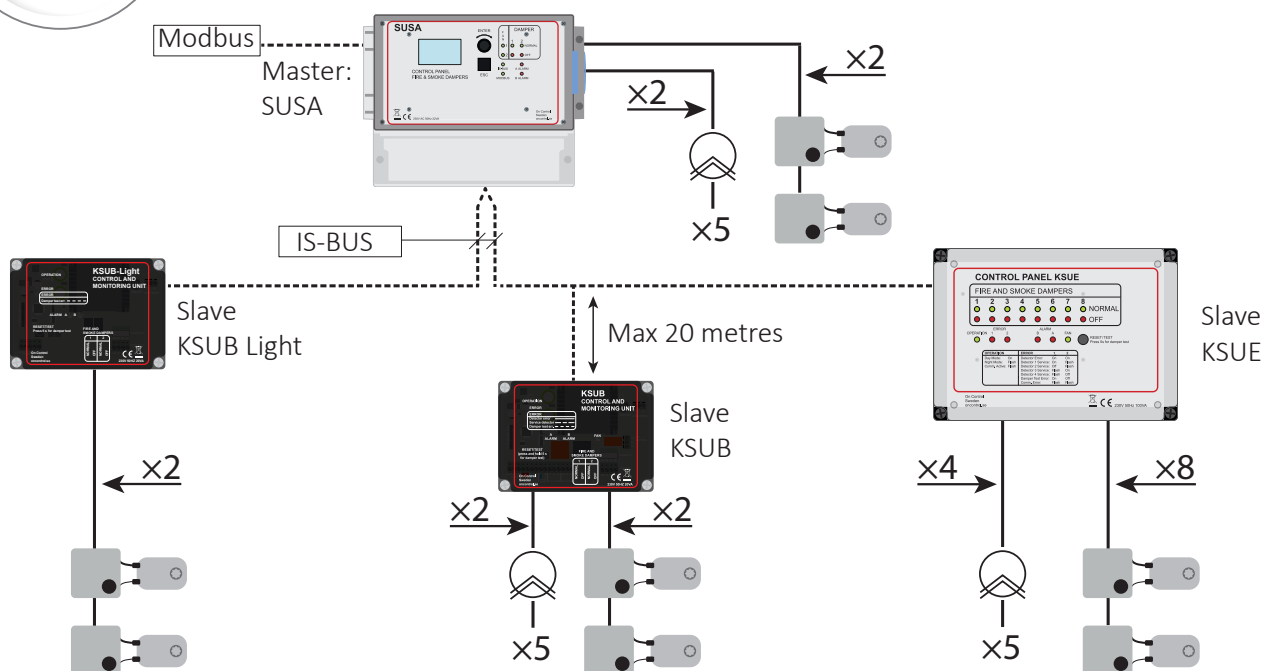

UNIT	FIRE DAMPER	SMOKE DETECTOR
SUSA	4 (2X2)	10 (2X5)
KSUE	16 (8X2)	20 (4X5)
KSUB	4 (2X2)	10 (2X5)
KSUB Light	4 (2X2)	0
KSUR	2 0-10 V	5

ACCESSORIES

KBOX

The KBOX connection box makes it much easier to connect an actuator to the control panel. It has labelled terminals and a built-in button to test the motor.

Two actuators can easily be linked to create a damper group (parallel connection).

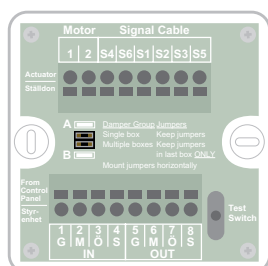

MAXIMUM CONFIGURATION

SUSA can also be used as the master for the slave units KSUB, KSUB Light, KSUE, KSUR, KSUD and KSUC, and supports our external alarm panel. The maximum number of slave units is 32. With the KSUE, the maximum number of damper groups is 256 + 2 in the SUSA. The SUSA has 2 smoke detector inputs which should be limited to 5 detectors per loop/input. Using slave units is a way of increasing the number of detector inputs. The KSUB is an alarming unit with 16 digital alarm inputs, for example for non-motorised dampers. The maximum number of inputs just with a KSUC is 512.

CONNECTIONS

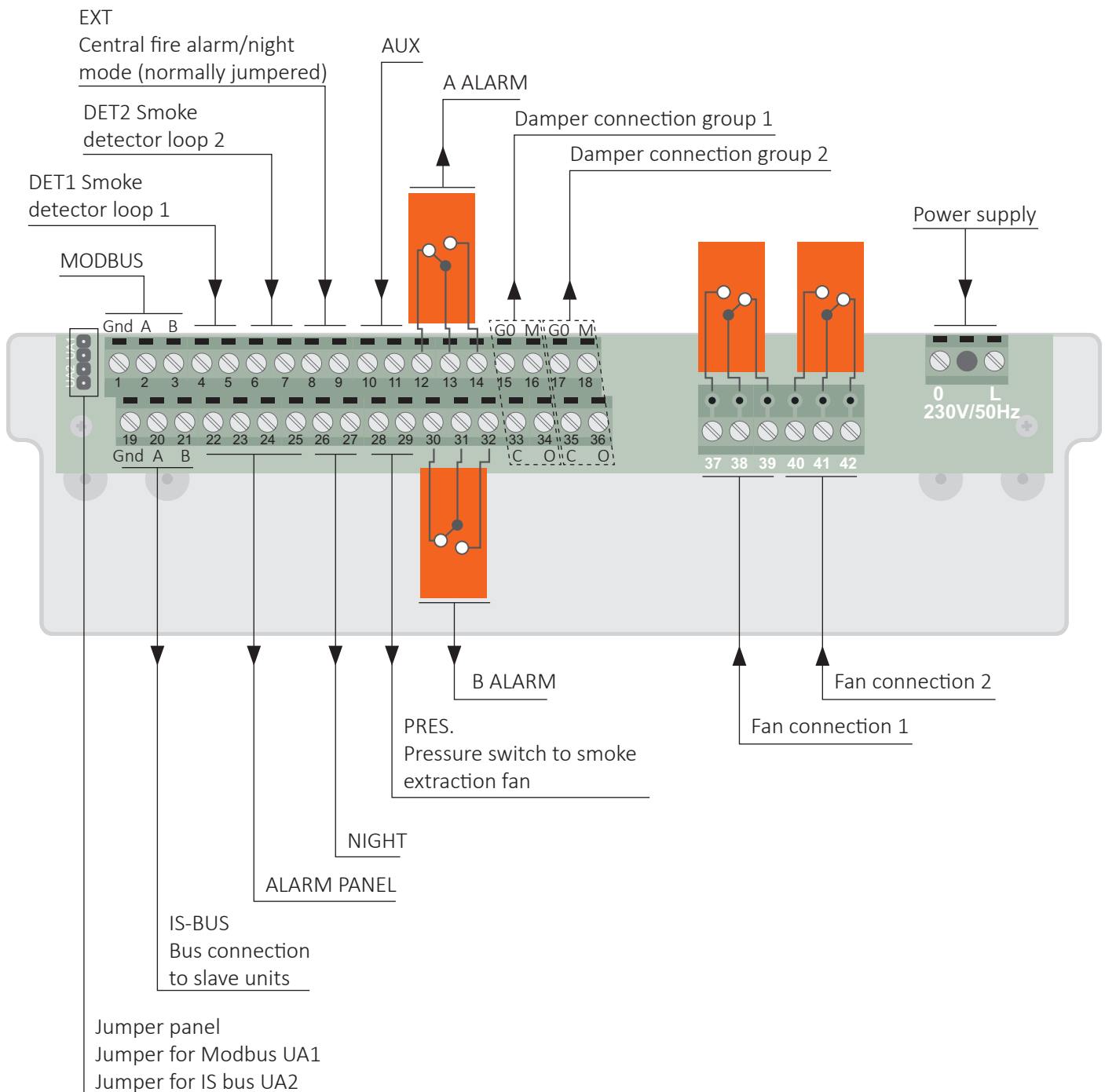

Wiring

The 230 V power supply must be connected via fixed cables to a group fuse of max 10 A / min 2 A. The SUSB is built with reinforced insulation, so no ground is necessary.

Relay outputs

All relays are shown in the open position. The normal factory setting is Fan 1 and 2 on. (37-38 and 40-41 closed) If there is an alarm, B alarm (sum alarm) is activated (for example) and 31-32 are closed.

Recommended cable

- The smoke detectors are connected using telephone type twisted pair cables with no particular requirements in terms of area.
- A damper motor can be connected using EKKX 1×4×0.5 for example.
 - One damper per damper group, max 100 metres
 - Two dampers per damper group, max 50 metres
- The IS-BUS network can be connected using FKAR-PG 2×0.5.

Operation

Max 20 VA / 3 min / Standby max 8 VA / 48 h

Wiring - INDIVIDUAL

Wiring - PARALLEL

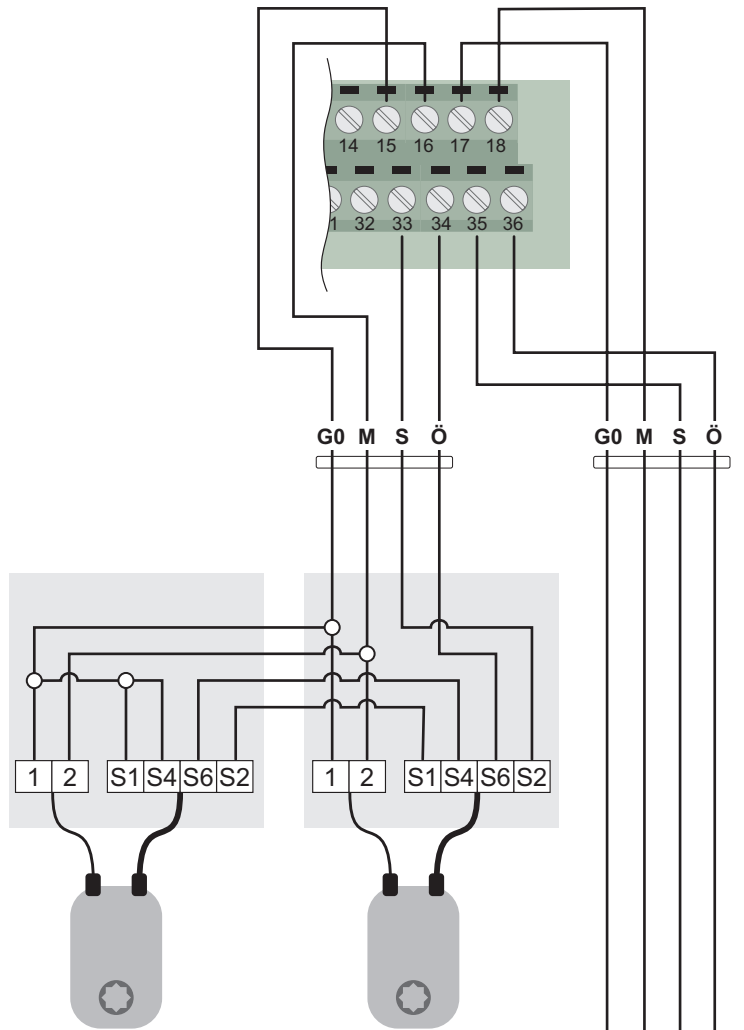
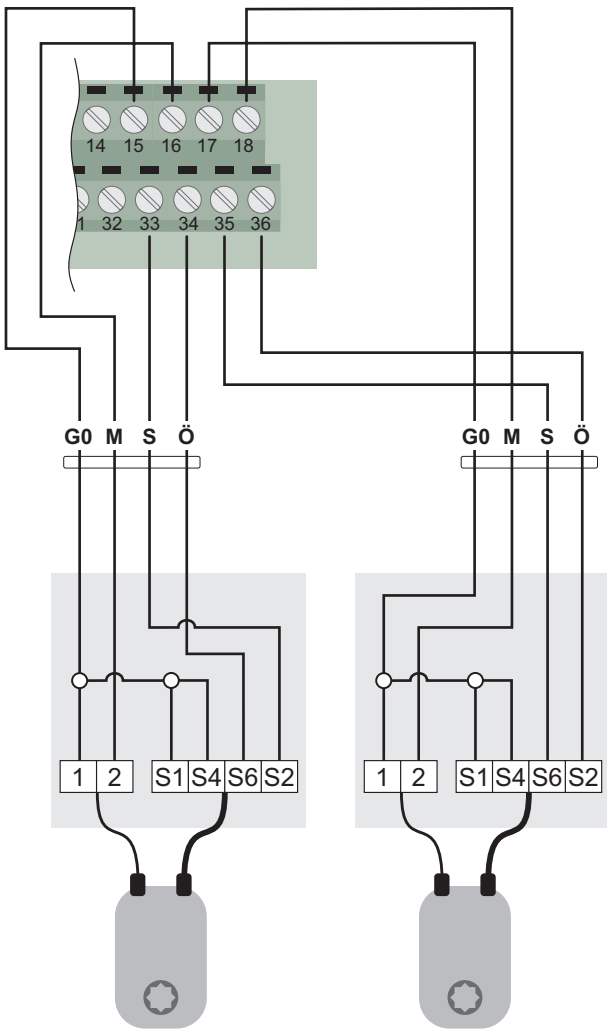

24 VAC fail-safe actuator (spring return)



Not used

Not used

Normal cable colours

1 - BLACK
2 - RED
S1 - VIOLET
S2 - RED
S3 - WHITE
S4 - ORANGE
S5 - PINK
S6 - GREY

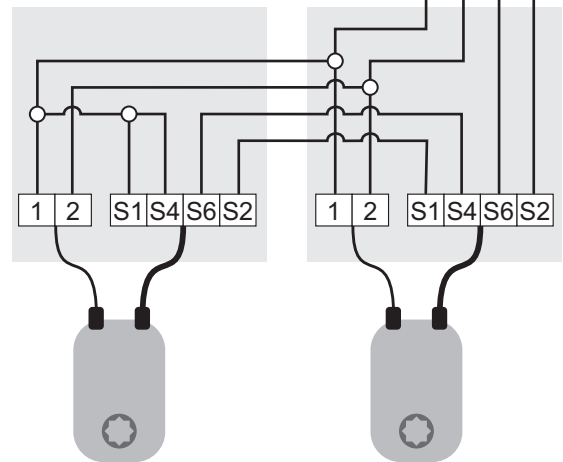

Fire damper connection

Fire dampers are connected as shown above and indicate NORMAL in the open position and OFF in the closed position (fail-safe position).

Evacuation (bypass) dampers are normally closed, indicated by the NORMAL LED. They open if there is a fire in the function group (indicated by the OFF LED). The damper motor closes the damper and the spring return opens it (fail-safe position). Connected as shown in the diagram below.



TIP!

The KBOX accessory has a PCB with labelled terminals and is recommended in order to simplify wiring.

WIRING WITH KBOX

You are recommended to use the KBOX connection box for easier wiring of 24 V fail-safe motors with spring return. The connection box also simplifies parallel connection and troubleshooting. See the drawing below.

Wiring - INDIVIDUAL

One damper per damper group.

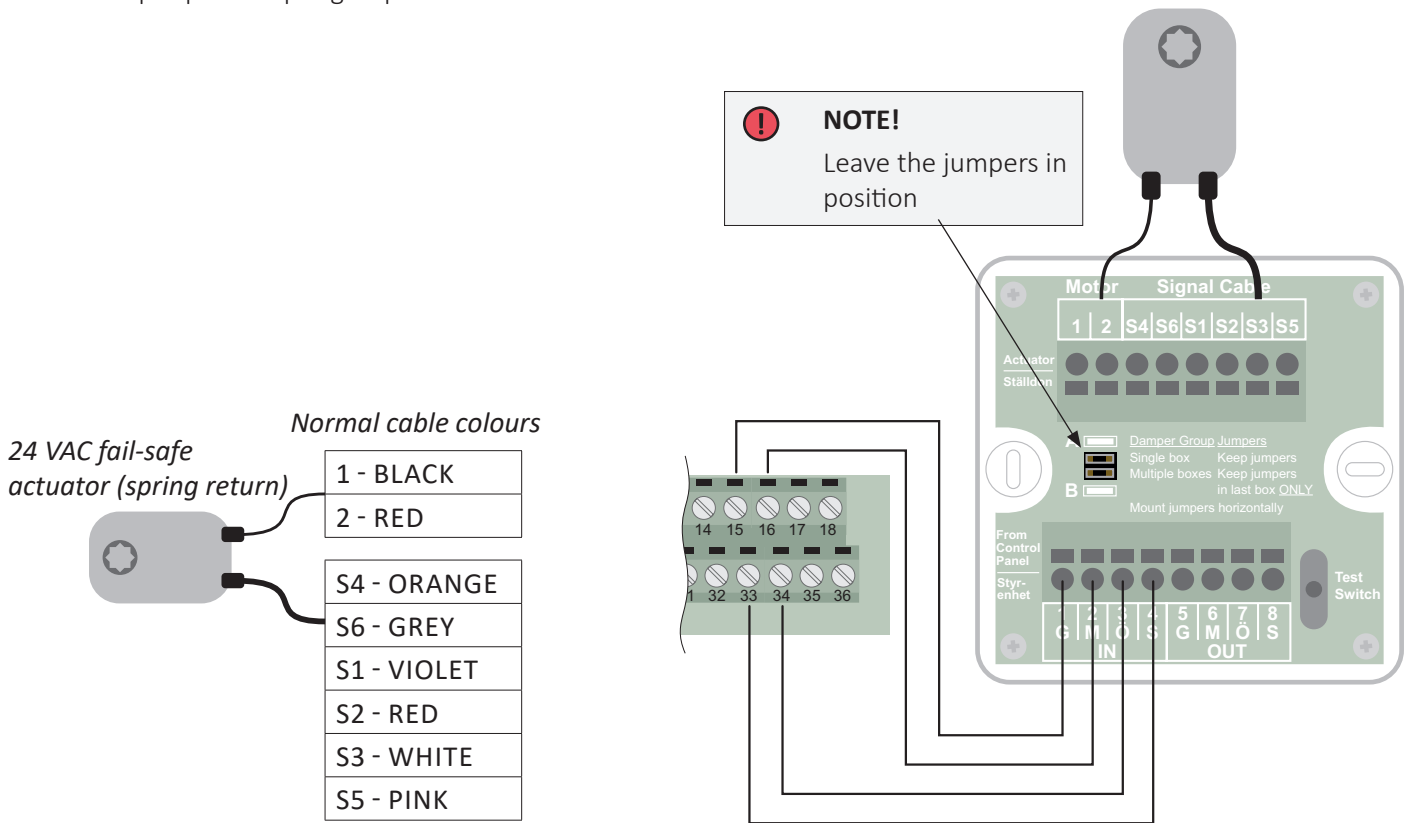

Wiring - PARALLEL

Two dampers per damper group.

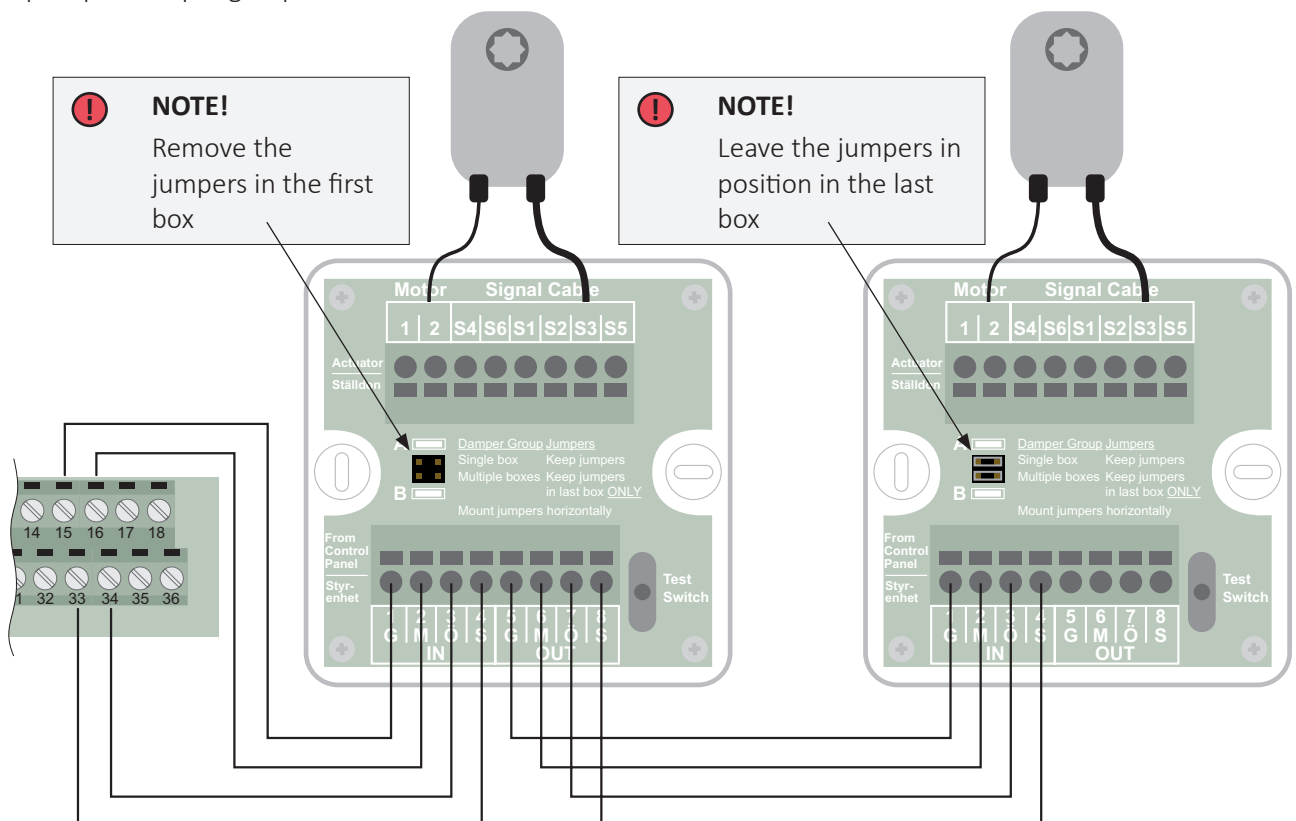

Slave unit wiring

The IS bus terminal (19/Gnd)(20/A)(21/B) is used to connect a network-attached slave unit (up to 32). The wiring diagram is shown below. Shielded two-wire cable is used to make the connections. Connect the shielding ONLY to Gnd in the SUSAs and Gnd in the slave units. Connect A to A and B to B in all units.

Cable length max 1200 m at least two-wire TP 0.5 mm² with shielding (Gnd) of type FKAR-PG or equivalent. If the cable is split as shown in the figure below, the branch must not be longer than 20 m.

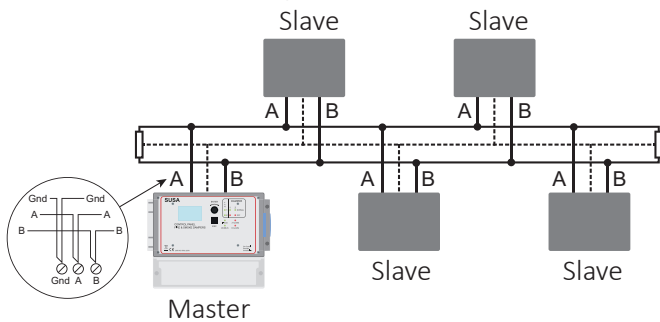

The network is terminated at the start and end.

The termination consist of a jumper on the PCB. In the SUSAs it is called UA2 and is located to the left of terminal number 1.

In the KSUB the jumper is called I and in the KSUE it is called TERM. There can only be 2 terminations in total.

AUX input

The function of this universal input is selectable.

1. The default setting is to stop the function test when the input closes.
2. Alternatively, the test will take place as soon as the input opens if the clock has already indicated that a test is due.
3. The AUX input is used for an external fire alarm in FG2. If this option is used, the normal fire alarm input is dedicated for FG1. For this option, the input must be NC.

Modbus

The Modbus connection is of type RTU and communicates via RS485. The communication parameters and the Modbus address are specified in the Modbus menu. The default setting on delivery is address 10, 9600 bps 8n2. To terminate the line, there is a built-in resistor which is activated by jumpering the pin marked UA1. The pin is situated to the left of terminal 1 in the SUSAs.

Modbus can be used to download a large amount of information from the system. With a connection to the network (IS-BUS), detailed information is available about each damper group. The same is true of all detector groups.

For more information about Modbus parameters, please see the separate document.

Reset

Choose "Alarm reset" from the menu to reset all alarms.

Function test

Choose "Manual tests" and the test type. Dampers are either tested in sequence or all at the same time depending on the configuration. The function test for the fire ventilation fan is completely separate. All dampers are tested with the smoke extraction fan, for the time configured in the evacuation fan settings.

Manual check of smoke extraction fan function

Choose MANUAL TESTS->START E FAN TEST.

The test starts and the ventilation system is stopped (if there is one). The dampers move to the fire position within the configured ventilation fan stop time, factory setting 30 seconds. After the evacuation dampers have opened, the smoke extraction fan starts. If there is a pressure sensor, it must close during the test. This is checked just before the fan stops running. The function test ends after the preconfigured time. The smoke extraction fan stops and everything returns to normal operation.

The monitoring menu indicates when the function test is running.

FIRST STARTUP

When you switch on the SUSA for the first time, there are some settings menus you need to work through before it can be used.

All the individual menus are described in the settings and only a few changes need to be made.

MENU	DESCRIPTION
Language <pre>Välj språk: Choose language: Valikun kieli: Vælg sprog: Svenska English Suomi Dansk</pre>	<p>The choice of language remains even after a factory reset.</p>
Damper test menu <pre>DAMPER TEST MENU Interval: 2 days Start day: Month: Start time: 01:00 Test type: Para.1&2 ENT=Change ESC=Next</pre>	<p>In this menu, choose how often and when you want the automatic function test of the dampers to take place. If you do not want a function test, set the interval to 0 days. The text changes to TEST OFF. The test interval does not begin until after the start day. If you choose an irregular test interval, the test takes place at the interval starting from the first test.</p> <p>Press ESC when you have finished.</p>
Date/time settings <pre>SET CLOCK 2021-05-23 17:30:00 Y Use summer time Y/N Turn = Move ENT = Change ESC = Next</pre>	<p>You can disable the automatic change from normal time (winter time) to summer time by clicking Y at the end of the clock setting, to change it to N.</p> <p>If everything looks OK, press ESC.</p>
Audible alarm signal <pre>AUDIBLE ALARM SIGNAL OFF TURN=Change ENT=Save ESC=Next</pre>	<p>An audible signal can be sounded for an alarm. There is a menu option to deactivate it.</p> <p>If the audible signal is active, a message appears in the INFO menu if an alarm occurs, explaining how to stop the sound signal. If a new alarm occurs, the audible signal starts again. The audible signal is used for A alarms and B alarms.</p> <p>A alarms have a more intensive sound than B alarms.</p> <p>There is an option to add our external alarm panel for public alarms.</p>
Confirm the changed settings <pre>CONFIRM SETTINGS 2021-05-23 17:58:30 DAMPER TEST: Interval: 2 days Start day: Month: Start time: 01:00 Test type: Para.1&2 ENT=Save ESC=Change</pre> <pre>CONFIRM SETTINGS Audible alarm signal: OFF ENT=Save ESC=Change</pre>	<p>A list of changed settings appears in the two next menus as a final reminder before the INFO menu is displayed.</p> <p>You can go back and change something, otherwise press ENT.</p> <p>You are now ready for configuration</p> <div style="border: 1px solid black; padding: 5px; margin-top: 10px;"> <p> NOTE!</p> <p>None of the dampers or detectors are preconfigured</p> </div>

DURING STARTUP

Start by configuring the directly connected (local) dampers in the SUSA.

The function group (FG) groups detectors, dampers and fan relays together. There are two FGs in the system. One, FG1, is used for ventilation dampers (fire dampers) and to stop a ventilation system. When the ventilation dampers are working as intended, you are ready to configure any smoke detectors and slave units you may have.

Factory settings

None of the dampers are activated on delivery. The detector inputs are not activated. The external fire input with terminals 8-9 are activated with automatic reset. Fan outputs 1 and 2 are in parallel and function group 1 is active. The clock function for the smoke extraction fan test is not activated. No slave units are activated.

INSTALLATION WITHOUT SLAVE UNITS	DESCRIPTION
<p>Once the detectors, dampers and other components are installed, the SUSA must be configured. Assume there is one smoke detector and two dampers to be closed if there is a fire (ventilation dampers). The smoke detector is connected to terminals 4-5 and the dampers are connected to 15-16-33-34 and 17-18-35-36.</p>	<p>Follow these steps:</p> <ul style="list-style-type: none"> ▪ Click with the knob to choose the Settings menu. ▪ Log in with AAAA. ▪ Choose "Damper menu" and click with the knob. ▪ Choose "Local damper list" and click with the knob. ▪ Choose "Damper 1" and click. ▪ Set the damper type to VENT and function group 1. ▪ Press ESC and repeat with Damper 2. ▪ Return to SETTINGS by pressing ESC three times. ▪ Turn the knob one step clockwise to the Detector menu and click. ▪ Choose "Local detectors" and click. ▪ Click once to display Detector 1 and FG1 in the menu. ▪ Press ESC to return to the info menu and finish.

INSTALLATION OF SLAVE UNITS	DESCRIPTION
<p>Activate the terminating resistor at each end of the network. You are recommended to test the slave units in standalone mode before connecting them to the network. They are delivered pre-configured for the test. When this is done, remove ALL the jumpers in the slaves and specify an address. The first slave has the address 0. (No jumpers in the address panel.) The next slave has the address 1, etc. Each slave has a unique address. No two slaves must have the same address. The software version must be at least 3.0 for a KSUB, at least 2.0 for a KSUE and at least 3.2 for a KSUC in order to work with the SUSA. The last two digits of the serial number indicate the software version in older units. In more recent units, it is FW3.0 for example.</p>	<p>Configuration</p> <ul style="list-style-type: none"> ▪ In the Settings menu choose "Slave unit menu". ▪ Choose "Slave unit list". ▪ For address 0 (00) click until the correct slave unit appears under "Unit". ▪ Continue in the same way with address 1 (01). ▪ After entering the correct slave units, press ESC. ▪ Hold down the knob for five seconds to create the damper and detector lists. ▪ Continue to the Damper menu and choose "Ext. damper list". ▪ You can now activate the inputs used in the slave units by specifying the damper type and function group. ▪ Define the detector connections in the same way in "External detectors".

Function test in night mode

In night mode, the function test can be run without special programming. The SUSA detects the damper positions and carries out the function test to the other position. The fans are only affected if they are fire ventilation fans.

A manual reset is required after night mode.

Requirement: there is a night mode signal from the time channel of the ventilation system, opening terminals 26-27 in the SUSA.

Locking may occur if night mode is indicated by the SUSA, which then sends a stop signal to the system via the fan lock. This locking may be bypassed by deselecting the "stop at night" option in the ventilation fan properties.

Priority handling

If an alarm (triggered detector or external fire alarm) is activated during the function test, the test is ended and the unit immediately switches to alarm state. Communication errors to slave units are treated as fire alarms except that the relay for triggered detector is not closed.

Fan control

There are two fan control outputs that are used differently depending on the configuration.

If the ventilation system is connected, the fan receives the stop signal as soon as smoke is detected.

For controlled operation, for example in a function test, the fan is given an adjustable delay of 0 to 600 seconds to reduce its speed before any damper is closed. The delay is also used to cool an electric air heater.

The fire ventilation fans can be controlled from one or two outputs on the SUSA. If two fans are connected, they are started with a 15 second interval if a detector is triggered. In a function test, the interval is 15 seconds. This prevents an unnecessarily high starting current if both fans start simultaneously.

Fan control via slave units

Fans can also be controlled by relays on the two slave units with the lowest addresses. The first slave address echoes the function from relay number 1 in the master unit, and the next slave address echoes the function from relay number 2 in the master unit.

Control clock

The control clock governs the function test (if there is one). The clock automatically switches between summer/winter time and is preset for a function test starting at 01:00 on Monday and then every other day. A function test can be set to run every day, every other day, every third day, etc. After six days the frequency switches to weekly. You can then select up to 52 weeks. The control clock for the smoke extraction fan test is completely separate from the damper test. The damper test can be scheduled for once a week, once a month or any number of months. You can specify the day of the week and date of the month.

Function test of smoke extraction fan with pressure switch

If the smoke extraction fan has a pressure switch, it can be connected to terminals 28-29 in the SUSA. After the smoke extraction fan is started via relay output fan 1 or fan 2 (depending on the selected configuration) in the SUSA, the pressure switch should close within the test time, otherwise a function test error and B alarm are indicated. If there is no pressure switch the input must be jumpered.

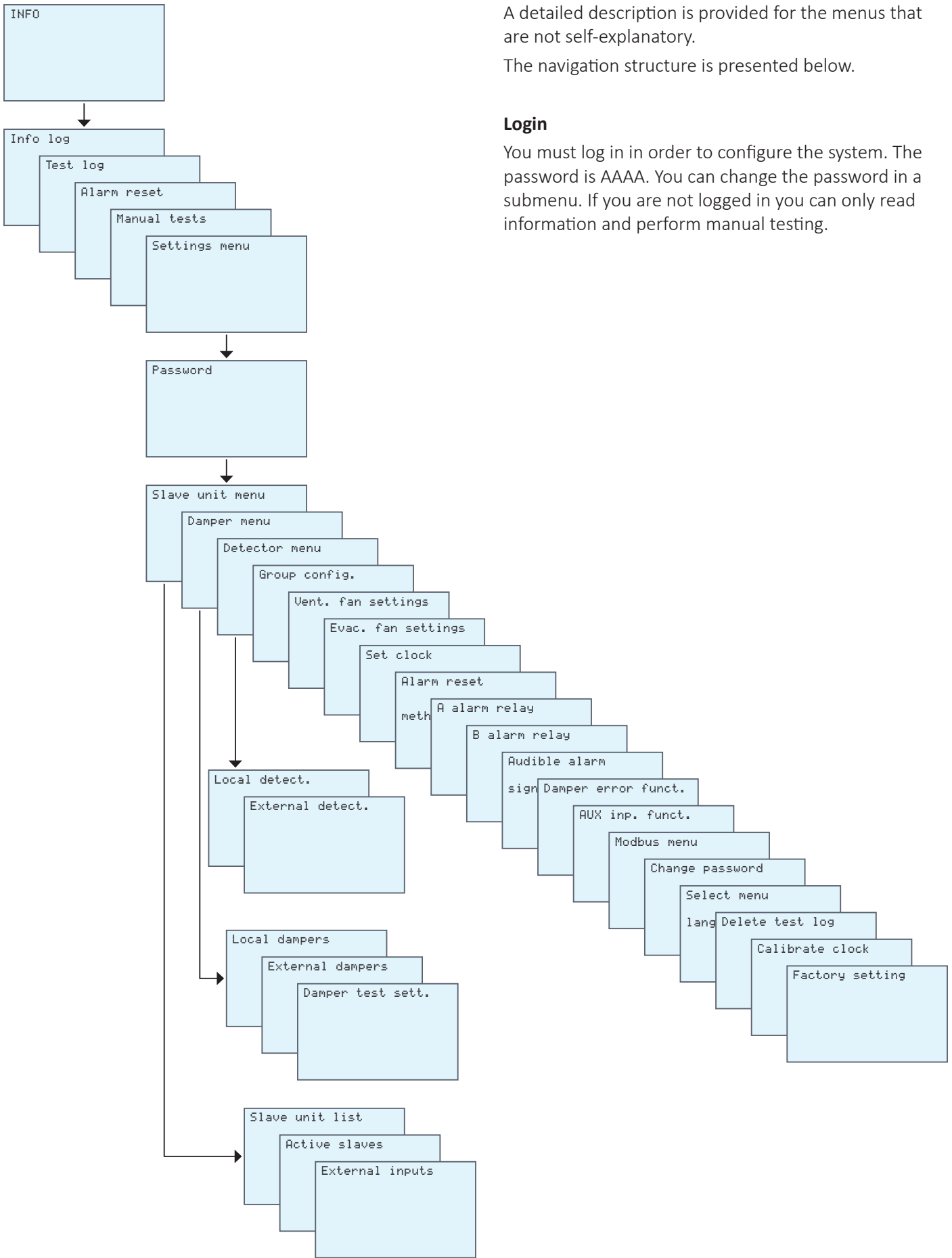

A detailed description is provided for the menus that are not self-explanatory.

The navigation structure is presented below.

Login

You must log in in order to configure the system. The password is AAAA. You can change the password in a submenu. If you are not logged in you can only read information and perform manual testing.

MENU SYSTEM

MENU	DESCRIPTION
INFO MENU <pre> Sun 21-05-23 17:59:07 ----- Status:OK Normal mode ----- Version 53.0 </pre>	<p>Status: OK</p> <p>The status indicates whether the system is alarm free and provides brief status information.</p> <p>Status: OK? means that the dampers are in an undefined position, e.g. during damper opening. Other operating information is also shown.</p>
Configuration of slave units <pre> CONNECTED SLAVE UNITS Address Unit ├─00 KSUB │ 01 KSUE │ 02 KSUB light │ 03 KSUC └─04 KSUR ENT=Change ESC=Back </pre>	<p>First, each of the slave units is physically assigned an address (see the product information for the particular unit).</p> <p>The same address number is then configured with the correct unit name in the list. When you have finished, press ESC. Hold down the knob for 5 seconds according to the instructions to save new damper and detector lists.</p> <p>Old lists are deleted.</p>
Configuration of external dampers <pre> EXTERNAL DAMPER LIST Dmp Position T FG ----- ▶1 KSUB-00-1 U 1 2 KSUB-00-2 - - 3 KSUE-01-1 E 1 └─4 KSUE-01-2 - - ENT=Change ESC=Back </pre>	<p>When the slave units are correctly configured, their connected dampers and detectors can be configured in EXTERNAL DAMPER LIST.</p> <p>The example here shows the first damper number in the system – number 1 (Dmp) – which is connected to a KSUB with address 00 in damper group 1 (DAMPER1). The damper is a ventilation damper in function group 1. The next example is damper number 3, which is connected to a KSUE with address 01 in damper group 1 (DAMPER1) and is an evacuation damper in function group 1.</p>
Disabling a slave unit temporarily <pre> ACTIVE SLAVE UNITS Address Unit ├─00 KSUB ├─01 KSUE ├─02 KSUB light ├─03 KSUC └─04 KSUR ENT=Change ESC=Back </pre>	<p>Slave units have an address. To allow them to be easily re-installed without having to create new lists, it is possible to disable a slave while retaining all other settings. This is a useful function when servicing or replacing slave units. Select the slave and click to remove the check mark next to the address.</p>
Installing local smoke detectors <pre> LOCAL DETECTORS FG ----- ├─Detector 1 1+2 └─Detector 2 --- ENT=FG ESC=Back </pre>	<p>To activate smoke detectors, select them from the relevant menu.</p> <p>The options for the function group are FG1, FG2 or 1+2. Choose 1+2 if you want the smoke detector to work with both groups, otherwise choose the relevant function group.</p>
Installing external detectors <pre> EXTERNAL DETECTORS Det Position FG ----- ▶1 KSUB-00-1 1+2 2 KSUB-00-2 1+2 3 KSUE-01-1 --- 4 KSUE-01-2 --- ENT=FG ESC=Back </pre>	<p>The menu is similar to the external damper list. In the example below, the first detector group in the system – number 1 – is connected to a KSUB with address 00 and the unit's detector group 1 (DET1).</p> <p>The detector is in function groups 1 and 2 (FG). Detector 2 below is connected to the same KSUB (00) and the unit's detector group 2 (DET2), and is also in function groups 1+2 (FG).</p>

MENU SYSTEM

MENU	DESCRIPTION
Function group configuration <pre> FUNCTION GROUP CONFIG. Fgroup- Type - Relay: ✓Fg1 - U - (Re1+Re2) Fg1-U-Re1, Fg1-E-Re2 Fg1-U-Re1, Fg2-U-Re2 Fg1-U-Re1, Fg2-E-Re2 Fg1-E-Re1, Fg2-E-Re2 ENT=FG ESC=Back </pre>	<p>Used to select the control of ventilation systems (V) or smoke extraction fans (E) with all settings.</p> <p>Fg:Function group, Re:Relay for ventilation system (V) and/or smoke extraction damper (E)</p>
Ventilation fan settings <pre> VENT.FAN SETTINGS ----- ▶Fan stop conditions Fan stop time ENT=Change ESC=Back </pre>	<p>The ventilation system settings can be found in "Fan stop conditions". There are a number of stop conditions.</p> <p>You can select a stop time between 0 and 600 seconds. If there is a fire, the stop time is always 0 seconds.</p>
Evacuation fan settings <pre> EVAC.FAN SETTINGS ----- ▶Fan start conditions Test running time Day of week for test Time for test ▼ Test running schedule ENT=Change ESC=Back </pre>	<p>Used to select the control of the smoke extraction fan. This menu also contains the function test settings for the smoke extraction fan.</p> <p>The smoke extraction fan can be set to start with a delay of 15 seconds, or it can be locked so that all evacuation fans must be open. The run duration is specified for the function test. (0-600 seconds)</p> <p>The day of the week and the time of the test can be specified with an interval.</p> <p>The test interval can be set to every week or once a month. All months can be selected.</p>
Damper test <pre> DAMPER TEST MENU ----- ▶Interval: 2 days Start day: Month: Start time: 01:00 Test type: Para.1&2 ENT=Change ESC=Back </pre>	<p>The damper test settings are configured in a submenu of the Damper menu.</p> <p>The test can be set to run every day, every other day, every third day, etc.</p> <p>After six days the frequency switches to weekly. The maximum interval that can be selected is 52 weeks. If you set the interval to 0 days, the automatic test is disabled.</p> <p>There are four different damper test modes to choose from.</p> <ol style="list-style-type: none"> 1. Parallel FG1&FG2. All dampers in both function groups are tested at the same time. 2. Sequential FG1&FG2. The dampers in function group 1 are tested sequentially at the same time as the dampers in function group 2. 3. Parallel FG1 > FG2. All dampers in FG1 are tested first, followed by all dampers in FG2. 4. Sequential FG1 > FG2. All dampers in FG1 are tested sequentially first, followed by all dampers in FG2. <p>The control unit of the ventilation system follows the test sequence so that one system at a time is stopped if desired.</p> <p>In a sequential test, each damper group is tested separately. It can take a very long time to complete a sequential test if the system has a large number of dampers.</p>
Alarm panel function	<p>The alarm panel is activated in the audible alarm signal menu.</p> <p>Wiring as shown on page sidan 4. The alarm panel is triggered by A alarms and B alarms. You can mute the alarm by pressing the button next to the alarm, leaving only the LED alarm. The alarm will not completely disappear until the alarm has been reset in the SUSA and the fault has been corrected in the installation. The on/off LED indicates that the alarm panel has a power supply, not that it is activated. Up to three alarm panels can be connected.</p>

SPECIFICATION

Attachment

Intended to be attached to a wall indoors.

Power supply

230 VAC, 50 Hz, 30 VA. Fused with max 10 A / min 2 A.

The mains voltage may vary $\pm 10\%$

Transient voltages up to overvoltage category II.

Enclosure degree of protection

IP65

Ambient temperature

Max +35 °C, min -10 °C

Altitude up to 2000 m

Max relative humidity 80% at temperatures up to 31 °C

Max relative humidity falls in a linear fashion to 50% at 40 °C

Weight

1.5 kg

Outputs

- B alarm (sum alarm). Voltage-free changeover contact 1 A max 24 VAC/DC 60 V. Terminal numbers 30-31-32.
- A alarm (triggered smoke detector and external fire alarm) shared by the two loops. Voltage-free changeover contact 1 A max 24 VAC/DC 60 V. Terminal numbers 12-13-14.
- Fan lock 1. Voltage-free changeover contact max 8 A / 24 VAC/DC. Terminal numbers 37-38-39.
- Fan lock 2. Voltage-free changeover contact max 8 A / 24 VAC/DC. Terminal numbers 40-41-42.

Dimensions

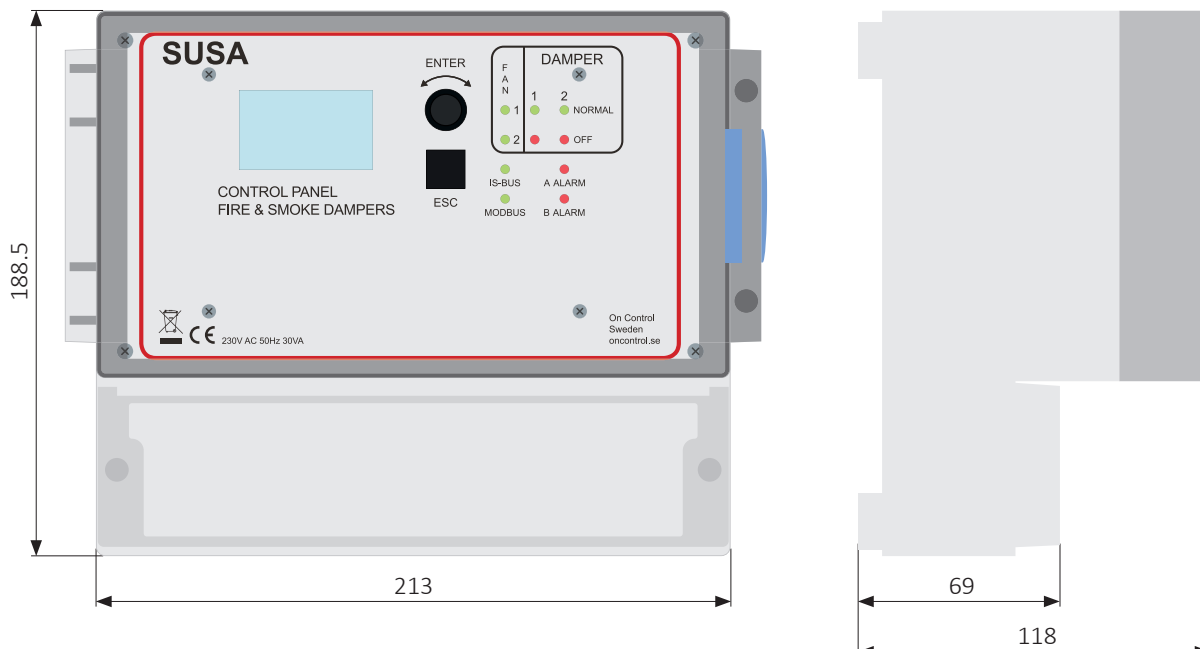

Inputs

- Smoke detector 1. Terminals 4-5.
- Smoke detector 2. Terminals 6-7.
- PRES. Terminals 28-29. Pressure switch from smoke extraction fan. Normally jumpered.
- NIGHT. Terminals 26-27. Night mode. Normally jumpered.
- EXT. External control unit. Opening the circuit has the same effect as a triggered smoke detector. (Both groups affected) Terminal numbers 8-9. Normally jumpered.
- AUX. Selectable input for various special cases. See also the description of AUX. Terminal numbers 10-11.
- External alarm panel. Terminals 22-23-24-25.
- Slave unit. IS-BUS Terminals 19-20-21.
- Modbus RTU. Network. Terminals 1-2-3.

Fuses

There is a 160 mA 250 V fuse (FS1) on the motherboard.

To access the fuse, remove the four screws in the corners of the front panel. Carefully place the panel to one side. Take extra care with the thin ribbon cable connecting the front panel with the connection card.

DO NOT let the front panel hang from the cable!

Instead, use the slots in the box to store it temporarily.

There is a fuse holder on the bottom right-hand side.

This is the primary fuse.

Pollution degree

Pollution degree 2 is valid for the intended environment.

Isolating switch

The installation must have an isolating switch or circuit breaker.

It must be easy to access at a suitable location.

It must be labelled as the isolating device for the equipment.

TERMINOLOGY

Dampers	This documentation refers to ventilation dampers and evacuation dampers. Ventilation dampers (fire dampers) are normally open and are closed by a spring. Evacuation dampers are sometimes called pressure relief dampers or bypasses. They are normally closed and they are opened by a spring.
Fans	A ventilation fan is also called a ventilation system. In this documentation, an evacuation fan is a smoke extraction fan or other extractor which starts when there is a fire.
Operating positions	In normal operation, all ventilation fans are open and the evacuation fans are closed. In night mode, all dampers are closed. Night mode is activated when the circuit is opened between terminals 26-27.
Night mode	All damper types close. For example, used if the ventilation system is shut down to save energy. The fire damper is put in the fail-safe position and then opens when the NIGHT input closes again. Damper tests (if any) can take place at this time.
Function groups	The SUSA consists of two halves called function groups. Each group has dampers, detectors and fan relays. All dampers and detectors must be assigned to one or both groups. The groups themselves have various group functions which can be set in the "Group config." menu. At present there are four options. One option is for just one group to be active, controlling detectors, dampers and fan functions in a shared configuration. This means that no division is possible.

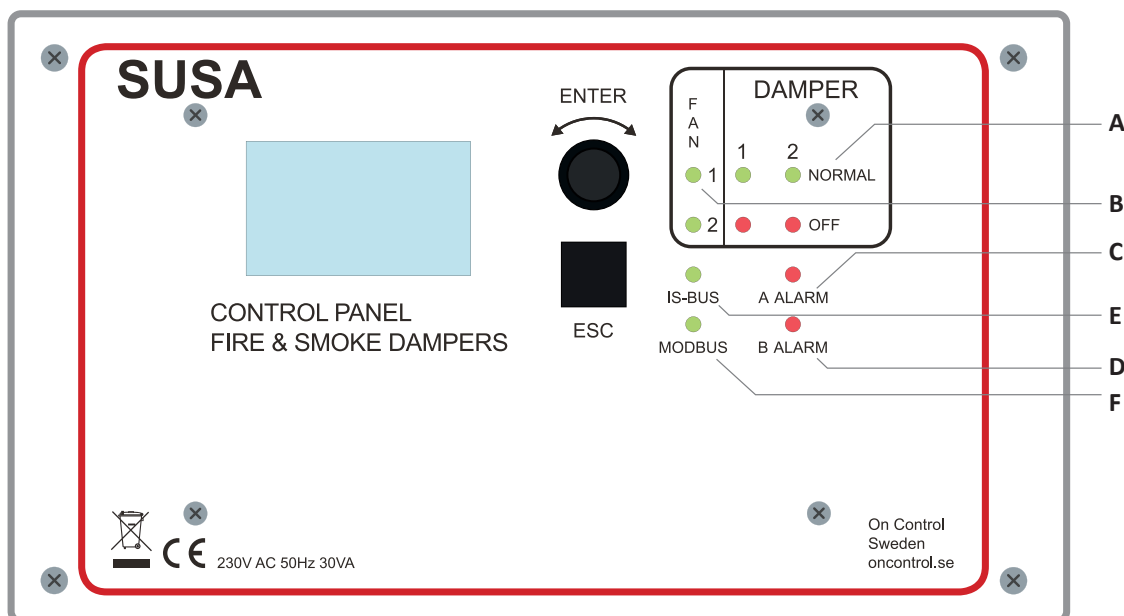

	FUNCTION	DESCRIPTION
A	DAMPER	<p>Indicates the end position of the safety actuator for the relevant damper group.</p> <ul style="list-style-type: none"> ▪ Green LED (NORMAL) indicates the normal position. <ul style="list-style-type: none"> ▪ Ventilation dampers are open in the normal position. ▪ Evacuation dampers are closed in the normal position. ▪ Red LED (OFF) indicates the off position. <ul style="list-style-type: none"> ▪ Ventilation dampers are closed in the off position. <p>Evacuation dampers are also known as pressure relief or bypass dampers. The damper groups are numbered 1 and 2.</p> <p>The dampers do not open.</p> <p><i>Check:</i></p> <ul style="list-style-type: none"> ▪ Check that there are no other alarms on the front panel. ▪ Check that the dampers indicate the position OFF or CLOSED in the unit(s) where they are installed. ▪ Check that slave units are correctly connected and addressed. ▪ Check that the dampers are configured in the SUSA.
B	FAN	<p>The two fan controls are indicated with separate LEDs which light up when the relevant relay is closed.</p> <p>See the relevant function group menu for the function of the two fan control outputs.</p> <p>A manual reset is required after an automatic function test.</p> <p>The "fan lock" output has probably been connected to the wrong input in the ventilation system, which has locked itself in fire mode as a result.</p>

	FUNCTION	DESCRIPTION
C	A ALARM	<p>Red LED indicates:</p> <ul style="list-style-type: none"> ▪ Smoke detector triggered ▪ EXT input activated <p>The A alarm relay closes when the LED lights up. There is a menu option to invert the relay.</p> <p>A ALARM LED lights up.</p> <p><i>Check:</i></p> <ul style="list-style-type: none"> ▪ Open the log and look up the error. ▪ Check that the EXT input is jumpered or closed by an external monitoring unit. ▪ Check for a short-circuit in one of the detector loops.
D	B ALARM	<p>The alarms indicated as B alarms are:</p> <ul style="list-style-type: none"> ▪ Incorrect damper position ▪ Damper function test error ▪ Smoke extraction fan function test error ▪ Break in any of the detector loops ▪ Smoke detector service alarm ▪ Slave communication error ▪ Alarm from KSUC input <p>The B alarm relay closes when the LED lights up. There is a menu option to invert the relay to indicate a power failure.</p> <p>B ALARM LED lights up</p> <p>Open the log and look up the error or errors.</p> <ul style="list-style-type: none"> ▪ If the B alarm slowly switches on and off and the "Damper in wrong position motor on" error is logged, the damper is connected wrongly. Terminals 15-16 and 17-18 (G and M) are probably the wrong way around.
E	IS-BUS	The green LED flashes when a correct message is received from a slave unit.
F	MODBUS	The green LED flashes when a correct message is received from the Modbus master (SCADA). This confirms that the communication parameters and checksum are correct when the message is received by the SUSA.



**Disposal of used electrical and electronic equipment
(applies to the EU and other European countries with a dedicated collection system)**

If this symbol appears on the product or its packaging, the product must not be treated as household waste. Instead, it must be sent to a suitable collection point that recycles electrical and electronic equipment. By making sure this product is correctly processed, you will help to prevent the negative impact on the environment and on human health that could result from inappropriate waste handling. Recycling helps to conserve natural resources. To find out more about recycling this product you can contact your local authority, your cleaning contractor or the dealer you purchased the product from.

PROFCON AB

Victor Hasselblads gata 9
421 31 Västra Frölunda
Sweden

Tel: +46 (0)33 25 65 70

Web: oncontrol.se

On Control is a registered trade mark of PROFCON AB